

**A LOT GOES INTO TODAY'S VARIABLE FREQUENCY SYSTEMS. OUR FLOW THRU™ TECHNOLOGY ENSURES IT ALL COMES OUT.**

Today's modern water systems deserve the best that the industry can offer. Ensure the safety and integrity of these systems by installing a Flexcon Flow-Thru™ tank product on every VFD installation. The unique patented designs provide total exchange of the water from the tank, thus preventing the possibility of stagnant water and dramatically reducing the potential for bacteria or algae growth. The Flow-Thru™ tank's two design configurations provide the utmost in installation flexibility.



**THE INDUSTRY LEADER IN INNOVATION QUALITY & SERVICE!**

- Patented Flow-Thru™ Connection
- Stainless Steel Construction
- Comprehensive testing
- 5 year limited warranty

**The Circulation Problem...**

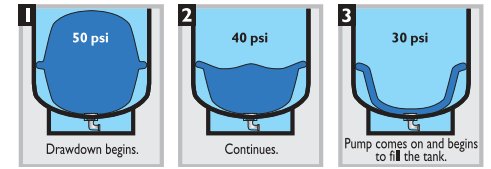

In a standard water system that operates with a pressure switch and a 20 PSI differential between cut-in and cut-out, the

water in the tank is flushed out and replenished on every pump cycle, thus greatly reducing the risk of stagnant water in the tank.

**The Flow-Thru™ Solution**

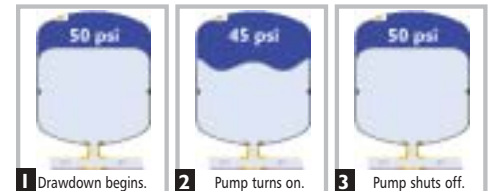

Newer variable speed drive systems operate on much lower differential pressures. They turn the pump on at a system pressure drop of as little as 2-5 PSI, and bring the pump up to speed very quickly. This means that the

water stored in the pressure tank is never fully exchanged, but merely diluted with new system water. This creates the possibility of stagnant water that remains in the pressure tank for an extended period of time.

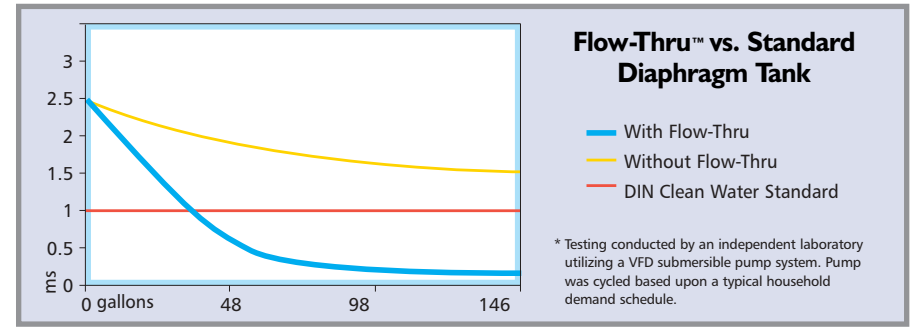

Model	Total Volume Gallons	Drawdown Volume Gallons	Dimensions (inches)			Weight (lbs)
			Diameter	Height	Length	
FT18	4.5	2	11"	NA	13.25"	10
FT18S	4.5	2	11"	12.6"	13.25"	12
FT44	14	6.2	16"	16.5"	20.80"	14

Connection: 1" Male NPT  
Precharge: 35 PSI  
Maximum Working Pressure: 125°F

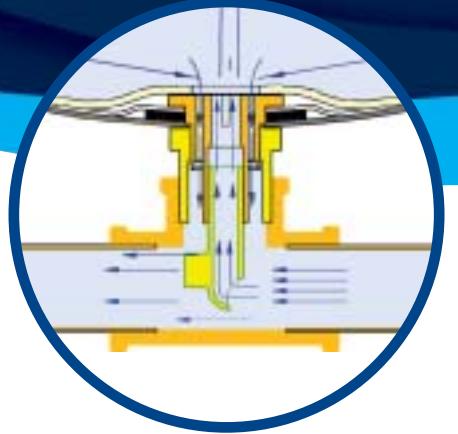

**Windvane Technology**

The patented Flow-Thru™ connection features an innovative windvane insert that diverts system water into and, more importantly, out of the tank while the pump is running. This flushing action assures that the water in the tank remains fresh and eliminates the possibility of stagnant water during normal system operation.



**FT 18**

**FT 18S**

**FT 44**

This 4.5 gallon total volume stainless steel tank includes the patented windvane insert. The brushed stainless steel tank resists corrosion and will look good for years to come.

This FT 18S includes two mounting feet and a stand which is perfect for mounting a VFD control box. Simply mount the feet to the wall with the connection in the horizontal or vertical position, and leave your customers with a neat compact installation that you can all be proud of!

The horizontal mount 14 gallon Flow-Thru tank is ideal for larger VFD systems where more storage is required or desired. It holds up to 6 gallons of system water and keeps it fresh!

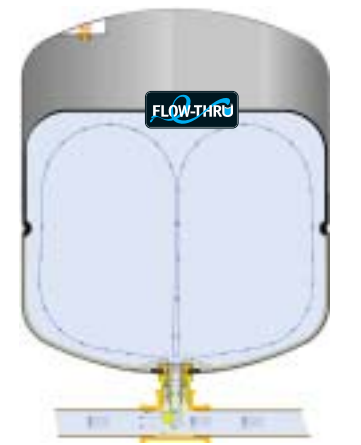

**Total Recirculation**

Flexcon's patented Flow-Thru™ technology assures total recirculation of the tank's water content within 50 gallons of system demand.\*

The Flow-Thru™ tank continues to circulate water through the tank whenever the pump is operating.